

# SAFE-T-PROOF™ Earthquake Fastener STP-MP-201: INSTALLATION INSTRUCTIONS

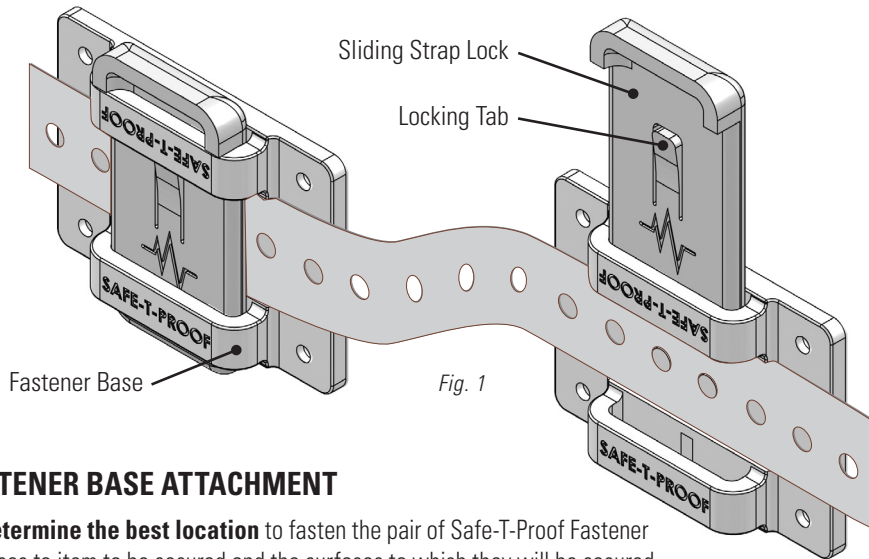

## FASTENER BASE ATTACHMENT

1. **Determine the best location** to fasten the pair of Safe-T-Proof Fastener bases to item to be secured and the surfaces to which they will be secured.
2. **Clean the selected surfaces** – on item to be fastened and on the surface where it will be secured – **with isopropyl alcohol and wipe dry**. This is very important in creating the best adhesion. Do not attach to surfaces that can peel off. Do not use other cleaning agents which may leave residues that can prevent the adhesive from fully attaching to the surface.
3. **Remove protective red sheet** from the adhesive pad on one fastener base. Hold the fastener base by its edges when handling. **Do not touch the adhesive surface once the protective sheet is removed.**
4. **Carefully place the fastener in position** (at the location determined in Step 1 and cleaned in Step 2) and attach the exposed adhesive. Remember, once the adhesive makes contact, that's where it's going to be.
5. **Press hard on the base** once attached in place to ensure good contact between the adhesive and surfaces.
6. **Repeat Steps 3 through 5** for the other fastener base. It is recommended that you **do not pull the strap taut before affixing any fastener base. Leave some slack in the strap so that the bond can set more thoroughly.**
7. **Let the fastener sit undisturbed for 72 hours** to ensure a proper bond.

**Screws:** Depending on the type of package you purchased, wood screws (for wood) and self-tapping screws (for metal) are included for situations that need reinforced attachment of the fastener base which have holes for them.

## STRAP ADJUSTMENT & RELEASE

**Releasing the Strap:** Press down the locking tab (shown in Fig. 1, above) and slide out the strap lock. The strap is instantly free to remove or adjust.

**Adjusting the Strap:** If simply adjusting strap length, lift and slip the strap into its new pins position and slide the strap lock back in place until the locking tab snaps to its lock position.

## APPLICATION TECHNIQUES for the Safe-T-Proof Fastener's 3M VHB Adhesive Tapes:

**CLEANING:** Most substrates are best prepared by cleaning with a 50:50 mixture of isopropyl alcohol (IPA\*) and water prior to applying the adhesive.

**Exceptions to the general procedure** that may require additional surface preparation include:

- **Heavy Oils:** A degreaser or solvent-based cleaner may be required to remove heavy oil or grease from a surface and should be followed by cleaning with IPA/water.
- **Abrasion:** Abrading a surface, followed by cleaning with IPA/water, can remove heavy dirt or oxidation and can increase surface area to improve adhesion.
- **Adhesion Promoters:** Priming a surface can significantly improve initial and ultimate adhesion to many materials such as plastics and paints.

## FASTENING STACKED EQUIPMENT

For securing stacked equipment, use the STP-MP-205-01. Order at [www.etcusa.net](http://www.etcusa.net) and indicate which color you need: putty or black.

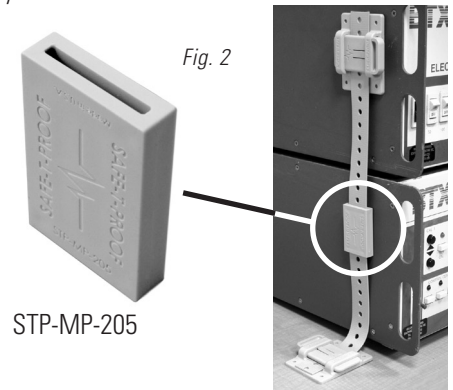

STP-MP-205

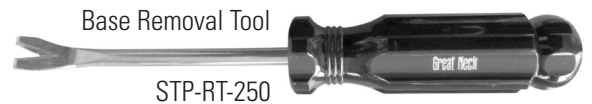

## BASE REMOVAL

### Removing Safe-T-Proof Fastener From Surfaces

1. Spray isopropyl alcohol around perimeter of the fastener base to be removed.
2. Using a prying tool, carefully and slowly pry off the adhesive from one corner of the fastener base (Fig. 3). Protect the surface by placing a piece of wood, plastic or metal under the prying tool you will use.
3. Remove the adhesive by pulling it back on itself (Fig. 4).
4. Once the adhesive is removed, it can be replaced and the Safe-T-Proof Fastener can be reused.

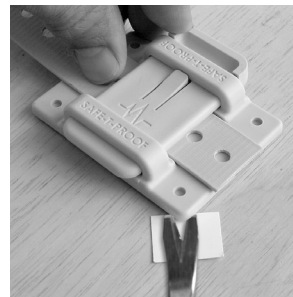

Fig. 3



Fig. 4

**FASTENING TO WALLS:** See reverse side for instructions on fastening to walls.

• **Porous Surfaces:** Most porous and fibered materials such as wood, particleboard, concrete, etc. need to be sealed to provide a unified surface.

• **Unique Materials:** Special surface preparation may be needed for glass and glass-like materials, copper and copper containing metals, and plastics or rubber that contain components that migrate (e.g. plasticizers).

• **Rough-Textured Surfaces:** Equipment surfaces that have a slightly rough texture (as is common with many refrigeration units) should be treated with an emery cloth before putting on the adhesive.

Scrub the area the fastener will be attached to with the emery cloth. Clean the surface once with the alcohol wipe to remove the particle that will be on the unit's surface after scrubbing. Allow to dry, and then clean a 2nd time with an additional wipe. Once the surface is dry, go ahead and affix the peel-and-stick fastener.

## FASTENING TO WALLS

1. **Locate studs on wall** using stud finder; mark its location.
2. **Check location of studs to the left and right** of the first stud you located. Note: Studs are normally 16 or 24 inches apart. So, when you locate a stud, check for studs to the left and right of that stud to make certain that it is a stud and not an electrical conduit or gas/water pipe.
3. **Based on the location of the studs, determine the best location** to attach the strap (to the wall) and the Safe-T-Proof Fastener base (to the item).
4. **Attach a fastener base to one end of a strap.** Then, insert the appropriate screw through a washer and then through the second hole at the other end of the strap. Lay your drill on its side on top of the item being fastened and drill the screw into the stud in the wall. Use a 2" wood screw for wood studs; use a 2" self-tapping screw for metal studs.
5. **Position the Safe-T-Proof base** in front of the stud on top of the item about 1" from the back of the item. Make sure there is some slack. Clean the area on the item where the base is to be attached, using isopropyl alcohol. Do not use other cleaning agents which may leave residues that can prevent the adhesive from fully attaching to the surface.
6. **Remove protective red sheet** from the adhesive pad on one fastener base. Hold the fastener base by its edges when handling. **Do not touch the adhesive surface once the protective sheet is removed.**
7. **Carefully place the fastener in position** (at the location determined in Step 3 and cleaned in Step 5) and attach the exposed adhesive. Remember, once the adhesive makes contact, that's where it's going to be.
8. **Press hard on the base** once attached in place to ensure good contact between the adhesive and surfaces.
9. **Repeat Steps 2 through 8** for the other fastener base.

## REINFORCING ATTACHMENT TO ITEM

If you want to reinforce the fastening on the item itself, you can use the shorter screws on the corners of the base.

**For wood** furniture or cabinet, use a drill bit size that is smaller than the screw diameter and pre-drill the holes through the designated screw locations at the 4 corners of the fastener base that should now be attached to the item via the adhesive. Drill a hole not deeper than the thickness of the cabinet or furniture.

**For metal** furniture or cabinet, use the self-tapping screws, no pre-drilling necessary.

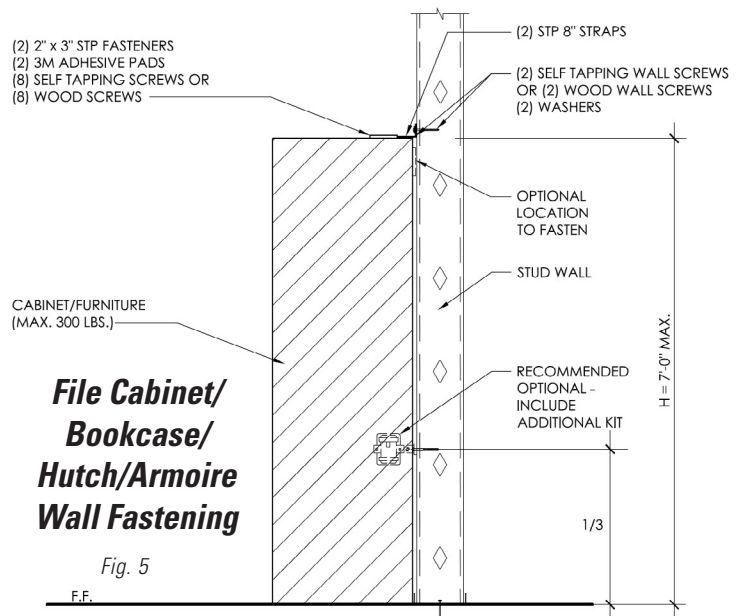

## OPTIONAL ATTACHMENT/REINFORCEMENT ON SIDES

If you want to put additional reinforcement, we recommend putting them on either side of the item. However, make sure you have studs accessible from the sides for wall attachment. Attach fasteners about 1/3 height from the floor level.

If doing all your attachments on the sides, attach at 1/3 height intervals on both sides. You will need an additional STP-MP-201 kit to add the side fastening or to put 2 fasteners on each side.

## Large Tabletop Equipment Fastening (Max. 375. lbs.)

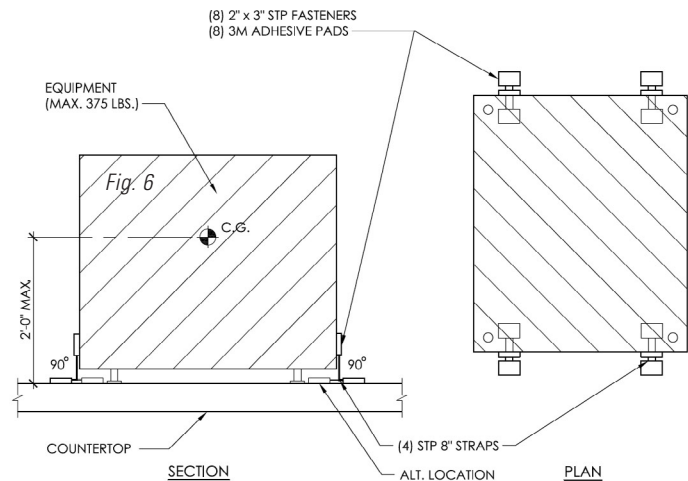

**NOTE:** Photo in Figure 2 (reverse page), and details in Figures 5 and 6 (above) only show suggested fastener locations based on common situations. Your Engineer of Record should design and approve your anchorage based on site-specific conditions and applicable codes.

**WARRANTY AND DISCLAIMER:** The SAFE-T-PROOF Earthquake Fastening System is sold under this warranty and disclaimer:

**WARRANTY:** Manufacturer warrants all parts to be in good working condition for a period of One Year providing maintenance and installation was done properly per the installation instructions.

**DISCLAIMER:** The user shall determine the suitability of the product for the intended use and shall assume all risk and liability in connection therewith; this will include all items sold or distributed by Essrig Taylor

Construction (ETC). User is required to read all instructions and follow the manufacturer's guidelines. ETC cannot accept any responsibility for bodily injuries and/or property damage that may occur during the use of its products. In addition, ETC cannot be responsible for any injuries or damage that result from a natural disaster or any act of God. ETC accepts no responsibility for improper installation of its products.



Distributed by:  
www.etcusa.net

For more information on preparedness products and services, visit our website at [www.etcusa.net](http://www.etcusa.net) or call us toll-free at **800-377-8888**